



KC304LFW ALL SS PANEL MOUNT

Our '300LFW' series gauge line is a high quality line of all stainless gauges. With a one piece design solid connection welded to case, this gauge is more solid and leak free than our competitors. These gauges can be supplied dry or liquid filled based upon your needs and application.

This gauge has been specifically designed with original equipment manufacturers in mind. It is typically used on chemical or food processing applications as well as any commercial or industrial application where stainless steel components are necessary.

SPECIFICATIONS:

Front Flanged Panel Mount Design

Dial Sizes: 2 1/2"

Connection Sizes: 1/4"MNPT

Stainless Steel Case And Bezel

Stainless Steel Internals & Connection

Connection Welded at Case

316SS Bourdon Tube

Liquid Filled (Dry Available)

Accuracy : 1.5 % Full Scale

(Special Accuracy Available Upon Request)

Dual Scale: PSI & Bar (x100=kPa)

Ambient temperature: FILLED: 30°F to 160°F

DRY: -30°F to 180°F



RANGE	CODE	Major In	Minor In
30/0"VAC	A	5	0.5
30/0/15	CB	5	0.5
30/0/30	CC	10	1
30/0/60	CD	10	1
30/0/100	CE	20	2
30/0/150	CF	20	2
30/0/300	CH	50	10
0/15	B	2	0.2
0/30	C	5	0.5
0/60	D	10	1
0/100	E	20	2
0/160	F	20	2
0/200	G	40	5
0/300	H	50	5
0/400	I	50	5
0/600	K	100	10
0/1000	M	200	20
0/1500	N	200	20
0/2000	O	400	50
0/3000	P	500	50
0/5000	R	1000	100
0/10,000	U	1000	100
0/15,000	V	2000	200

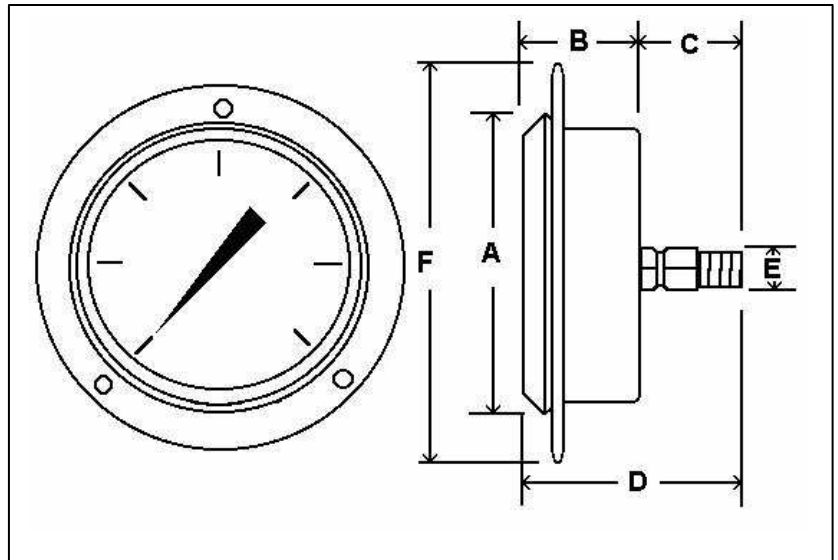

		A	B	C	D	E	F	G
2 1/2" Dial	In	2.80	1.28	1.19	2.46	1/4" NPT	3.48	2.50
	MM	71	33	30	63		88	64